



XG0607DC

MOBILE ELEVATING WORK PLATFORM

Comply with AS/NZS/ANSI/CE



XG0607DC

MOBILE ELEVATING WORK PLATFORM

Main Features

- Compact design fits through narrow aisles, doorways and elevators
- Efficient DC drive system, better power-saving than hydraulic drive
- Proportional drive gives smooth control
- Zero emission and non-marking tires ensure environment-friendly operation
- Zero turning radius enables better manoeuvrability

Product Parameters

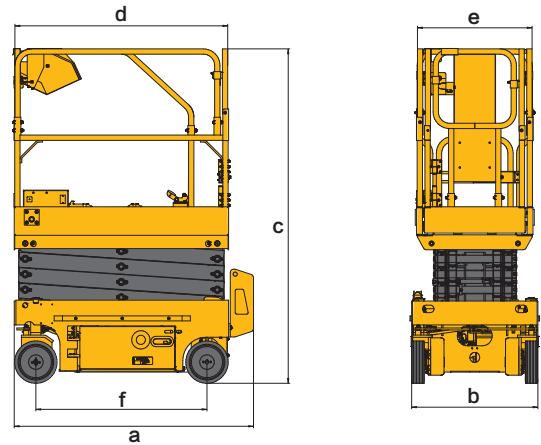

Item	Unit	XG0607DC
Max. Working height	m	5.6
Max. Platform height	m	3.6
Load capacity	kg	230
Load capacity of extended platform	kg	90
Max. Occupant Capacity		2
Min. ground clearance (pit protector rising/descending)	mm	65/15
Min. Turning radius (inner/outer wheel)	m	0.4/1.55
Lifting motor	kW	1.3
Lifting/Descending duration of platform	s	27-37/23-33
Max. Traveling speed at low level	km/h	4
Max. Traveling speed at high level	km/h	0.5
Max. gradeability	%	25
Max. Inclination (side/forward and backward)	°	1.5/2.5
Battery	v/Ah	2×12/85
Charger	v/A	24/15
Tire specification	—	254×76
Total machine weight	kg	920
a Overall length(no ladder)	mm	1440(1290)
b Overall width	mm	760
c Overall height (platform folded)	mm	2020(1660)
d×e Working platform dimension (Length×Width)	mm	1290×700
Length of extension platform	mm	600
f Wheelbase	mm	1030

XCMG Australia

Head Office: XCMG Mining Equipment Australia Pty Ltd

Tel: 04 1159 1394

Sales Email: royrossini@xcmg.com duhui2@xcmg.com

Add: Level 10 185 Victoria Square, Adelaide SA5000